



# TILTSTROBE

# IP



# USER MANUAL



## Table of contents

1. Safety Instructions .....	3/4
2. Technical Specification .....	5/6
3. Control Menu .....	7/8
4. DMX Channels .....	9/13
5. Fixture Dimensions .....	14
6. Trouble Shooting .....	14
7. Fixture Cleaning .....	15

## Statement

The product has well capability and intact packing when leave factory. All of the user should comply with warning item and manual, any misuse cause of the damages are not included in our guarantee, and also can not be responsible for any malfunction & problem owing to ignore the manual.



# 1.Safety Instructions

Please keep this User Guide for future consultation. If you sell the unit to another user, be sure that they also receive this instruction booklet.

- Unpack and check carefully there is no transportation damage before using the unit.
- Before operating, ensure that the voltage and frequency of power supply match the power requirements of the unit.
- It's important to ground the yellow/green conductor to earth in order to avoid electric shock.
- The unit is for indoor use only. Use only in a dry location.
- The unit must be installed in a location with adequate ventilation, at least 50cm from adjacent surfaces. Be sure that no ventilation slots are blocked.
- Disconnect main power before replacement or servicing.
- Make sure there are no flammable materials close to the unit while operating as it is fire hazard.
- Use safety cable when fixes this unit. DO NOT handle the unit by taking its head only, but always by taking its base.
- Maximum ambient temperature is  $T_a$ : 40°C. DO NOT operate it where the temperature is higher than this Unit surface temperature may reach up to 85°C. DO NOT touch the housing bare-hand during its operation. Turn off the power and allow about 15 minutes for the unit to cool down before replacing or serving.



- the event of serious operating problem, stop using the unit immediately. Never try to repair the unit by yourself. Repairs carried out by unskilled people can lead to damage or malfunction. Please contact the nearest authorized technical assistance center. Always use the same type spare parts.
- DO NOT touch any wire during operation as high voltage might be causing electric shock.

**Warning:**

- To prevent or reduce the risk of electrical shock or fire, do not expose the unit to rain or moisture.
- The housing, the lenses, or the ultraviolet filter must be replaced if they are visibly damaged.

**Caution:**

- There are no user serviceable parts inside the unit. DO NOT open the housing or attempt any repairs yourself. In the unlikely event your unit may require service, please contact your nearest dealer.

**Installation:**

- The unit should be mounted via its screw holes on the bracket. Always ensure that the unit is



## 2. Technical Specification

### Strobe Panel LEDs

LED Type: 5050 0.5W RGB 3in1 LEDs

LED Count: 480 LED Colors: RGB

LED Segments: 8 (2 x 4)

### Strobe Tube LEDs

LED Type: 3535 5W 6500K LEDs

LED Count: 144

LED Colors: Cool-White LED Segments: 4

### Movement

Resolution: 8-16 Bit

Tilt (Degrees): 185°

### Control

Control Modes: 7CH / 14CH / 42CH / 15CH / 43CH Display: Illuminated graphic LCD

Protocol: USITT DMX-512, RDM

RDM: Bidirectional communication

Wireless DMX: 2.4 GHz W-DMX™ (optional)

Cooling: Temperature controlled, overheating protection

### Effects

Dimmer: 0-100% electronic Shutter: electronic, max. 20 Hz

Internal Effects: LED Macro Effects

### Connectors

Signal connection: Seetronic IP65 XLR 3-Pin In/Out

Power Input: Seetronic PowerCON TRUE1 In/Out



## **Operating Conditions**

Mains voltage: 100-240V AC / 50-60Hz

Power: 1000W

Maximum ambient temperature: -30°C / 86°F, 50°C / 122°F Operating Position: any

## **Mounting Options**

Hanging: Omega-Bracket

Safety wire attachment: foldout eyelets

## **Shipping**

Single fixture: cardboard (inner and outer cartons) Tourpack: 4-way Flight Case

## **Housing Colors**

Standard colors: black

## **Dimensions**

Length: 482 mm / 18.9 in

Width: 178 mm / 9.0 in

Height (head horizontal): 243 mm / 9.5 in

## **Weight**

N.W: 10 kg

G.W: 12.5 kg



### 3. Control Menu

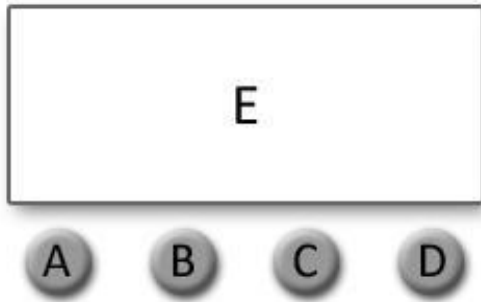

- A. MENU
- B. UP
- C. DOWN
- D. CONFIRM
- E. DIGITAL DISPLAY WINDOW

Display:

- MENU To select the programming functions (press to unlock screen)
- DOWN To go backward in the selected functions
- UP To go forward in the selected functions
- ENTER To confirm the selected functions

Set DMX Address:

1. Press "MENU" to unlock screen, then select the "DMX Address" and press "ENTER".
2. Showing "Set DMX Address 001", Press the "UP or DOWN" key to increase or decrease the DMX address value.

Press "ENTER" to save and Exit, Press "Cancel" does not save and Exit



Level 1	Level 2	Description
<b>DMX Address</b>	001-512	Set DMX address
<b>DMX Channel Mode</b>	DMX_CH7	7 channels DMX mode
	DMX_CH14	14 channels DMX mode
	DMX_CH42	42 channels DMX mode
	DMX_CH15	15 channels DMX mode
	DMX_CH43	43 channels DMX mode
<b>Dimmer Mode</b>	DIM1	Dimmer mode 1
	DIM2	Dimmer mode 2
	DIM3	Dimmer mode 3
	DIM4	Dimmer mode 4
	DIM5	Dimmer mode 5
<b>Mode Selection</b>	DMX512	DMX mode
	Auto1	Auto run mode 1
	Auto2	Auto run mode 2
	Auto3	Auto run mode 3
	Y motor	Tilt movement
	White	Beam dimmer
	W stroboscopic	Beam strobe
	Red	Back light red dimmer
	Green	Back light green dimmer
	Blue	Back light blue dimmer
RGB stroboscopic	Back light strobe	
<b>System Setting</b>	Language	语言/English
	Bk_Light	OFF/ON
	Dmx512	Clear/Keep
	W-DMX	Link/Unlink ( W-DMX version only )
<b>System Info</b>	RDM UID	RDM UID
	Version	Software Version Number
	DMX Channel	Currently used mode



## 4. DMX Channels

### 7 Channel mode

Channel	Name	DMX Value	Description
1	Tilt	0-255	Tilt Movement
2	Beam Dimmer	0-255	Beam Intensity
3	Beam Strobe Mode	0-5	No Strobe
		6-42	Strobe Mode 1
		43-85	Strobe Mode 2
		86-128	Strobe Mode 3
		129-171	Strobe Mode 4
		172-214	Strobe Mode 5
		215-255	Strobe Mode 6
4	Plate Red	0-255	Plate Red Dimmer
5	Plate Green	0-255	Plate Green Dimmer
6	Plate Blue	0-255	Plate Blue Dimmer
7	Plate Strobe	0-9	No Strobe
		10-255	Strobe from slow to fast

### 14 Channel mode

Channel	Name	DMX Value	Description
1	Tilt	0-255	Tilt Movement
2	Tilt Fine	0-255	Tilt Fine Movement
3	Beam Dimmer	0-255	Beam Intensity
4	Beam Strobe Mode	0-5	No Strobe
		6-42	Strobe Mode 1
		43-85	Strobe Mode 2
		86-128	Strobe Mode 3
		129-171	Strobe Mode 4
		172-214	Strobe Mode 5
		215-255	Strobe Mode 6
5	Reserved		Reserved Channel
6	Beam Macro	0-15	Beam Off
		16-57	Beam Macro 1
		58-99	Beam Macro 2
		100-141	Beam Macro 3
		142-183	Beam Macro 4
		184-225	Beam Macro 5
		226-255	Beam Macro 6
7	Plate Red	0-255	Plate Red Dimmer



8	Plate Green	0-255	Plate Green Dimmer
9	Plate Blue	0-255	Plate Blue Dimmer
10	Plate Strobe	0-9	No Strobe
		10-255	Strobe from slow to fast
11	Plate Macro	0-4	Plate Macro Off
		5-9	Plate Macro 1
		10-14	Plate Macro 2
		15-19	Plate Macro 3
		...	Plate Macro ...
		250-254	Plate Macro 50
		255	Plate Macro 51
12	Plate Macro Color	0-255	Plate Macro Color
13	Plate Macro Speed	0-255	Speed From Slow To Fast
14	Reserved	0-255	Reserved Channel

### 15 Channel mode

Channel	Name	DMX Value	Description
1	Tilt	0-255	Tilt Movement
2	Tilt Fine	0-255	Tilt Fine Movement
3	Beam Dimmer	0-255	Beam Intensity
4	Beam Strobe Mode	0-5	No Strobe
		6-42	Strobe Mode 1
		43-85	Strobe Mode 2
		86-128	Strobe Mode 3
		129-171	Strobe Mode 4
		172-214	Strobe Mode 5
		215-255	Strobe Mode 6
5	Reserved		Reserved Channel
6	Beam Macro	0-15	Beam Off
		16-57	Beam Macro 1
		58-99	Beam Macro 2
		100-141	Beam Macro 3
		142-183	Beam Macro 4
		184-225	Beam Macro 5
		226-255	Beam Macro 6
7	Plate Red	0-255	Plate Red Dimmer
8	Plate Green	0-255	Plate Green Dimmer
9	Plate Blue	0-255	Plate Blue Dimmer
10	Plate Strobe	0-9	No Strobe
		10-255	Strobe from slow to fast
		0-4	Plate Macro Off



11	Plate Macro	5-9	Plate Macro 1
		10-14	Plate Macro 2
		15-19	Plate Macro 3
		...	Plate Macro ...
		250-254	Plate Macro 50
		255	Plate Macro 51
12	Plate Macro Color	0-255	Plate Macro Color
13	Plate Macro Speed	0-255	Speed From Slow To Fast
14	Tilt Speed	0-255	Tilt Speed From Fast To Slow
15	Dimmer Speed	0-255	Dimmer Speed From Fast To Slow

## 42 Channel mode

Channel	Name	DMX Value	Description
1	Tilt	0-255	Tilt Movement
2	Tilt Fine	0-255	Tilt Fine Movement
3	Beam Dimmer	0-255	Beam Intensity
4	Beam Strobe Mode	0-5	No Strobe
		6-42	Strobe Mode 1
		43-85	Strobe Mode 2
		86-128	Strobe Mode 3
		129-171	Strobe Mode 4
		172-214	Strobe Mode 5
		215-255	Strobe Mode 6
5	Reserved	0-255	Reserved Channel
6	Beam Macro	0-15	Beam Off
		16-57	Beam Macro 1
		58-99	Beam Macro 2
		100-141	Beam Macro 3
		142-183	Beam Macro 4
		184-225	Beam Macro 5
		226-255	Beam Macro 6
7	Plate Red	0-255	Plate Red Dimmer
8	Plate Green	0-255	Plate Green Dimmer
9	Plate Blue	0-255	Plate Blue Dimmer
10	Plate Strobe	0-255	Plate Strobe
11	Plate Macro	0-4	Plate Macro Off
		5-9	Plate Macro 1
		10-14	Plate Macro 2
		15-19	Plate Macro 3
		...	Plate Macro ...



		250-254	Plate Macro 50
		255	Plate Macro 51
12	Plate Macro Color	0-255	Plate Macro Color
13	Plate Macro Speed	0-255	Speed From Slow To Fast
14	Tilt Speed	0-255	Tilt Speed From Fast To Slow
15	Beam Pixel 1	0-255	Tube Pixel 1
16	Beam Pixel 2	0-255	Tube Pixel 2
17	Beam Pixel 3	0-255	Tube Pixel 3
18	Beam Pixel 4	0-255	Tube Pixel 4
19	Plate Pixel 1 Red	0-255	Plate Pixel 1 Red Dimmer
20	Plate Pixel 1 Green	0-255	Plate Pixel 1 Green Dimmer
21	Plate Pixel 1 Blue	0-255	Plate Pixel 1 Blue Dimmer
...	...	...	...
40	Plate Pixel 8 Red	0-255	Plate Pixel 8 Red Dimmer
41	Plate Pixel 8 Green	0-255	Plate Pixel 8 Green Dimmer
42	Plate Pixel 8 Blue	0-255	Plate Pixel 8 Blue Dimmer

#### 43 Channel mode

Channel	Name	DMX Value	Description
1	Tilt	0-255	Tilt Movement
2	Tilt Fine	0-255	Tilt Fine Movement
3	Beam Dimmer	0-255	Beam Intensity
4	Beam Strobe Mode	0-5	No Strobe
		6-42	Strobe Mode 1
		43-85	Strobe Mode 2
		86-128	Strobe Mode 3
		129-171	Strobe Mode 4
		172-214	Strobe Mode 5
		215-255	Strobe Mode 6
5	Reserved	0-255	Reserved Channel
6	Beam Macro	0-15	Beam Off
		16-57	Beam Macro 1
		58-99	Beam Macro 2
		100-141	Beam Macro 3
		142-183	Beam Macro 4
		184-225	Beam Macro 5
		226-255	Beam Macro 6
7	Plate Red	0-255	Plate Red Dimmer
8	Plate Green	0-255	Plate Green Dimmer
9	Plate Blue	0-255	Plate Blue Dimmer



10	Plate Strobe	0-255	Plate Strobe
11	Plate Macro	0-4	Plate Macro Off
		5-9	Plate Macro 1
		10-14	Plate Macro 2
		15-19	Plate Macro 3
		...	Plate Macro ...
		250-254	Plate Macro 50
		255	Plate Macro 51
12	Plate Macro Color	0-255	Plate Macro Color
13	Plate Macro Speed	0-255	Speed From Slow To Fast
14	Tilt Speed	0-255	Tilt Speed From Fast To Slow
15	Beam Pixel 1	0-255	Tube Pixel 1
16	Beam Pixel 2	0-255	Tube Pixel 2
17	Beam Pixel 3	0-255	Tube Pixel 3
18	Beam Pixel 4	0-255	Tube Pixel 4
19	Plate Pixel 1 Red	0-255	Plate Pixel 1 Red Dimmer
20	Plate Pixel 1 Green	0-255	Plate Pixel 1 Green Dimmer
21	Plate Pixel 1 Blue	0-255	Plate Pixel 1 Blue Dimmer
...	...	...	...
40	Plate Pixel 8 Red	0-255	Plate Pixel 8 Red Dimmer
41	Plate Pixel 8 Green	0-255	Plate Pixel 8 Green Dimmer
42	Plate Pixel 8 Blue	0-255	Plate Pixel 8 Blue Dimmer
43	Dimmer Speed	0-255	Dimmer Speed From Fast To Slow



## 5. Fixture Dimensions

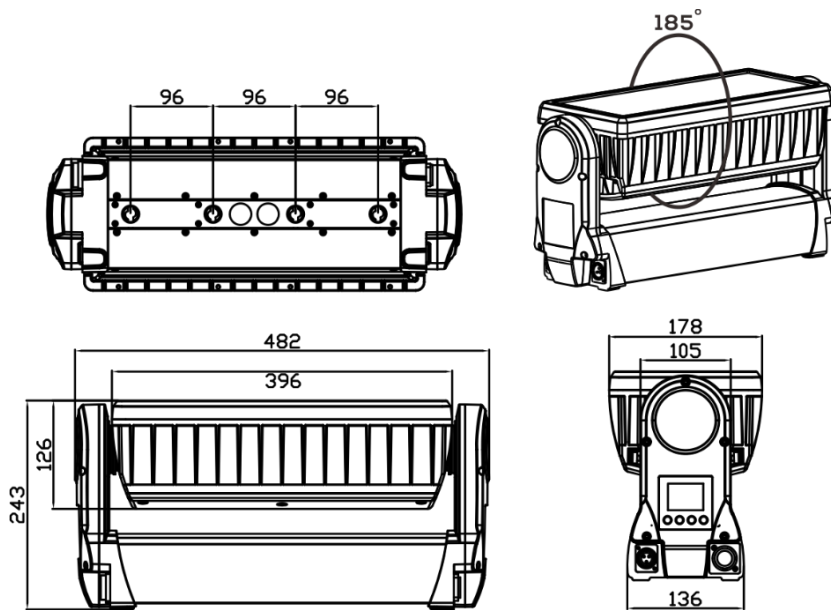

## 6. Trouble Shooting

Following are a few common problems that may occur during operation. Here are some suggestions for easy troubleshooting:

### A. The unit does not work, no light and the fan does not work

1. Check the connection of power and main fuse.
2. Measure the mains voltage on the main connector.
3. Check the power on LED.

### B. Not responding to DMX controller

1. DMX LED should be on. If not, check DMX connectors, cables to see if link properly.
2. If the DMX LED is on and no response to the channel, check the address settings and DMX polarity.
3. If you have intermittent DMX signal problems, check the pins on connectors or on PCB of the unit or the previous one.
4. Try to use another DMX controller.
5. Check if the DMX cables run near or run alongside to high voltage cables that may cause damage or interference to DMX interface circuit.



### **C. One of the channels is not working well**

1. The stepper motor might be damaged or the cable connected to the PCB is broken.
2. The motor's drive IC on the PCB might be out of condition

## **7. Fixture Cleaning**

The cleaning of internal and external optical lenses and/or mirrors must be carried out periodically to optimize light output. Cleaning frequency depends on the environment in which the fixture operates: damp, smoky or particularly dirty surrounding can cause greater accumulation of dirt on the unit's optics.

Clean with soft cloth using normal glass cleaning fluid. Always dry the parts carefully.

Clean the external optics at least every 20 days. Clean the internal optics at least every 30/60 days.

